



FIRE FIGHTING PUMP SYSTEM

STANDARD



According to NFPA 20
According to BS EN733

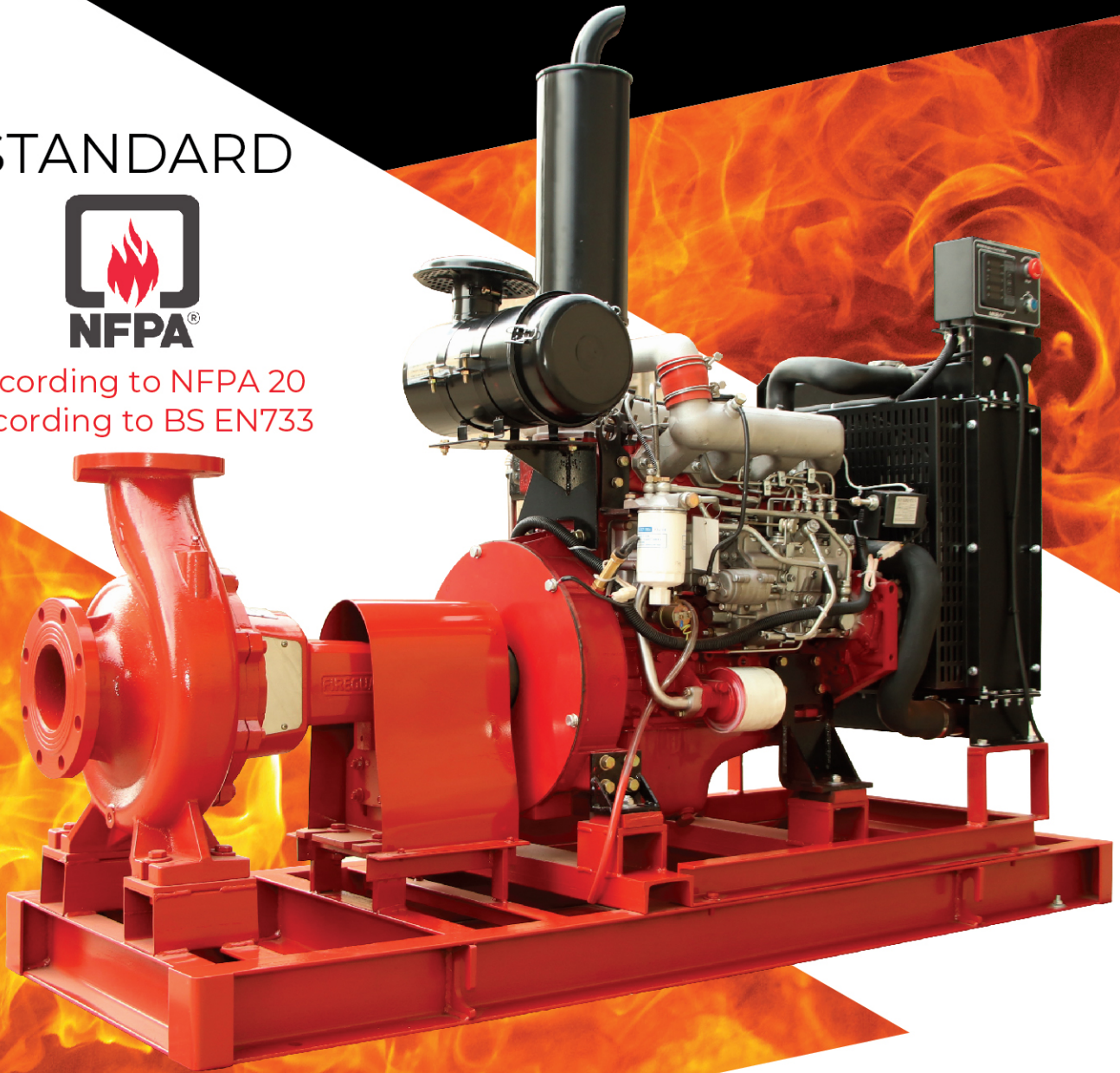

250GPM@8Bar

FIREGUARD GLOBAL LTD.

Tel: 00-44-8450751042 · Fax: 00-44-8459751043
Email: Info@Fireguard-Uk.com · www.fireguard-Uk.com

Unit 11 · Chancel Industrial Estate · Newhall Street
Willenhall · WV13 1NX · United Kingdom





Fire fighting pumping station

MODEL FGEDJ 250-8-30-32-3

Elctrical Pump Model FGSM 50-250/220

Diesel Pump Model FGSD 50-250/220

Jockey Pump Model FGVT 4-12

DESCRIPTION

- **FGEDJ** Fire pumps are designed for long term operational life, the maximum reliability is always our first priority.
- The components are installed on high rigidity steel structure.
- Each controller has its own individual pressure sensing line or pressure switch.
- The suction line doesn't include a strainer(Prefer anti vortex plate).
- Each pump has a dedicated controller.
- Each pump is tested for performance per the designed system requirments before dispatching from the factory.

FGEDJ Fire Pump Set consists of End Suction Centrifugal Pump driven by Electric Motor, Diesel Motor, and Vertical multistage Jockey Pump. Pumps are assembled with discharge line and suction header accessories as well as controls.

The capacity from 250GPM up to 2500GPM and other capacity can be customized.

Accessories include Battery, OS&Y Gate Valves, Check Valves, Flexible Expansion Joints, Pressure Switches, Pressure Gauge, Base Frame, etc.

Advantages

- Working Automatically among the three pumps.
- Both Manual and Automatic operation modes are available.
- Diesel Pump work when the power is off.
- Easy Installation.
- Customized size: Pump set or individual are available based on client requirement.
- FGYE high efficient motor with protection degree IP55.
- Insulation class F.
- High performance and low power consumption.
- Pump case with Anti-corrosive coating with quality NSK bearings, wear resistance mechanical seal.
- Control available upon request.
- Low maintenance cost and available spare parts.
- Electronic battery charger.

TECHNICAL DATA

MODEL	DN mm	Power		GPM	H(bar)	H(max) m	V	V	Cl	IP	A	Hz	T max	ph	min-1
		kw	hp												
Electric Pump FGSM 50-250/220	65x50	22	30	250	8	89.5	380	660	F	55	42.2/24.4	50	100	3	2900
Diesel Pump FGSD 50-250/220	65x50	24	32	250	8	89.5	/	/	/	/	/	50	100	3	2900
Jockey Pump FGVT 4-12	32x32	2.2	3	25	9	114	220	380	F	55	8.2/4.7	50	100	3	2900

Suction Side Size		Discharge Side Size	
Pipe	Valve	Pipe	Valve
4"-(DN100)	3"-(DN80)	4"-(DN100)	3"-(DN80)



TECHNICAL SHEET

Model	FGSM 50-250-220
Capacity	250 GPM
Head	8 bar
H max (Cut off head)	8.95 bar
DN	65*50 mm
Speed	2900 rpm
T max	100°C
Power	30HP - 22kW
Casing	Gray cast iron
Impeller	Bronze - DN: 250 mm
Shaft	Stainless steel 304
Sealant	Mechanical Seal
Bearing	Grease lubrication rolling bearing
Voltage	380v/3ph/50hz
Protection degree	IP55
Motor winding insulation class	F
Power connection	Star/Delta
Current	42.2/24.4
HZ	50

Electric Motor Driven Pump

A standby provider of flow and pressure to the system in case of failure of the main pump and/or power supply is off.

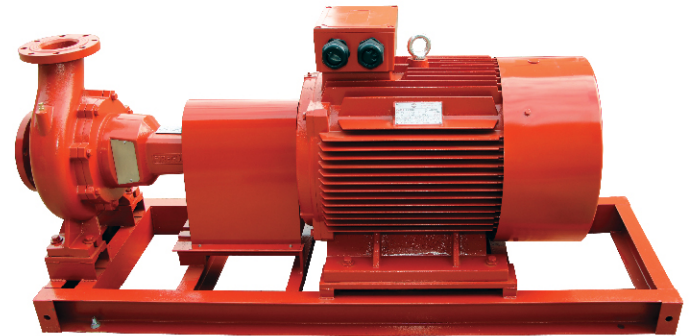

End Suction Centrifugal Pump FGSM

DESCRIPTION

- Designed according to EN733 standard centerifugal pump.
- Available complete with electric motor or diesel engine.
- Easily back pull-out from driver.
- Pump case with anti-corrosive coating.
- Quality NSK bearing, wear resistance mechanical seal.
- According to NFPA 20, water fire centrifugal pump shall be of the overhung impeller design with close or separate coupled end suction type.
- Pump capacities are available based on the required calculated system demand.
- Fire pump shutoff head dosen't exceed 140% of the duty point.
- Recommended the maximum system demand flow correlate to a point on pump curve between 90% to 140% of the pump capacity.
- Pump head not less than 65% @flow rate equal to 150% of the operating point.

Pump dismantle

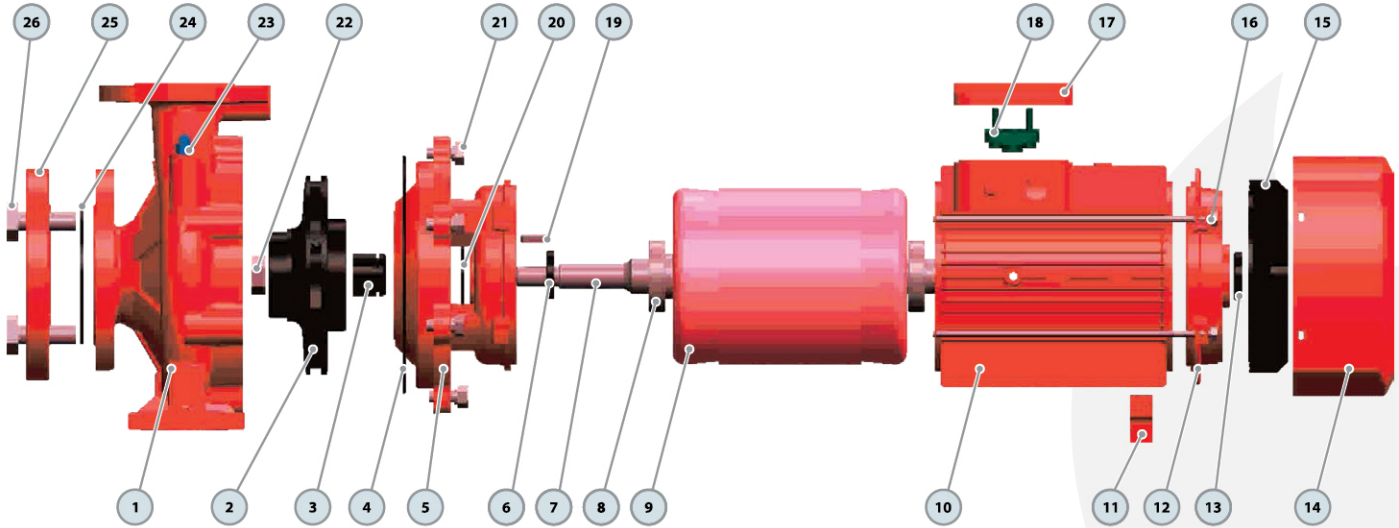

MATERIAL DESCRIPTION

No.	Description	Material	No.	Description	Material	No.	Description	Material
1	Pump Case	Cast iron	10	Motor Case	Aluminum	19	Impeller Key	Iron
2	Impeller	Bronze	11	Support Foot	Plastic	20	Water Deflector	Rubber
3	Mechanical Seal	SiC/Carbon/SS304	12	Back Cover	Cast iron	21	Connection Bolt	Steel
4	O-ring	Rubber	13	Reinforced Seal	Rubber	22	Impeller Nut	Galvanized Steel
5	Connection	Cast iron	14	Fan Cover	Aluminum	23	Release Valve	Brass
6	Reinforced Seal	Rubber	15	Fan	Plastic	24	Gasket	Rubber
7	Shaft	SS304/45# Steel	16	Through Bolt	Steel	25	Counter Flange	Galvanized Cast iron
8	Bearing	Ball Bearing	17	Terminal Box	Aluminum	26	Flange Bolt	Steel
9	Wound Stator/Rotor	Silicon Steel/Copper	18	Terminal Board	Plastic			

Electric motor TEFC type FGYE

- Design according to IEC60034 standard
- Total enclosed fan cooling type motor(TEFC)
- FGYE high efficient motor
- Protection degree IP55
- Motor winding Insulation Class F
- Quality NSK bearing
- Continuous duty S1
- Reliable used for fire fighting system etc.
- Ambient temperature up to +50°C
- Service of factor (1.15)

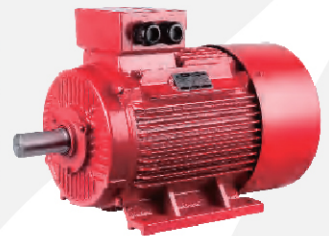
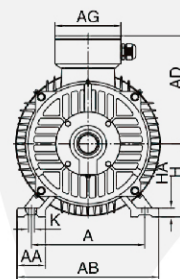
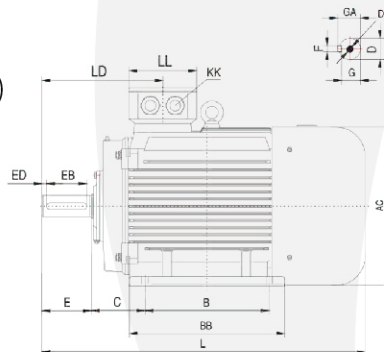

TECHNICAL DATA

50 Hz n=2900 1/min

MODEL	Power kw	Power hp	RPM 1/min	η %	η 75%	η 50%	$\cos \Phi$	A	Nm	Ts/Tn	Tmax/ Tn	Is/In	dB(A)	Kgs
FGYE-180M-2	22	30	2955	91.7	91.7	90.8	0.89	42.2/42.4	71.1	2	2.3	8.2	90	182

DIMENSIONS mm

MODEL	A	AA	AB	AC	AD	AG	B	BB	C	D	DH	E	EB	ED	F	G	GA	H	HA	K	KK	L	LD	LL
180M	279	70	349	355	267	162	241	311	121	48	M16X36	110	90	10	14	42.5	51.5	180	22	4-Ø14.5	2-M40X1.5	688	271	152

TECHNICAL SHEET

Model	FGSD 50-250/220
Capacity	250 GPM
Head	8 bar
Head Max (Cut off head)	8.95 bar
DN	65*50 mm
Speed	3000 rpm
T max	100°C
Power	24kW - 32HP
Casing	Gray cast iron
Impeller	Bronze - DN: 250mm
Shaft	Stainless steel 304
Sealant	Mechanical Seal
Bearing	Grease lubrication rolling bearing
Voltage	12 VDC
HZ	50

Diesel Engine Driven Pump

A standby provider of flow and pressure to the system in case of failure of the main pump and/or power supply is off.

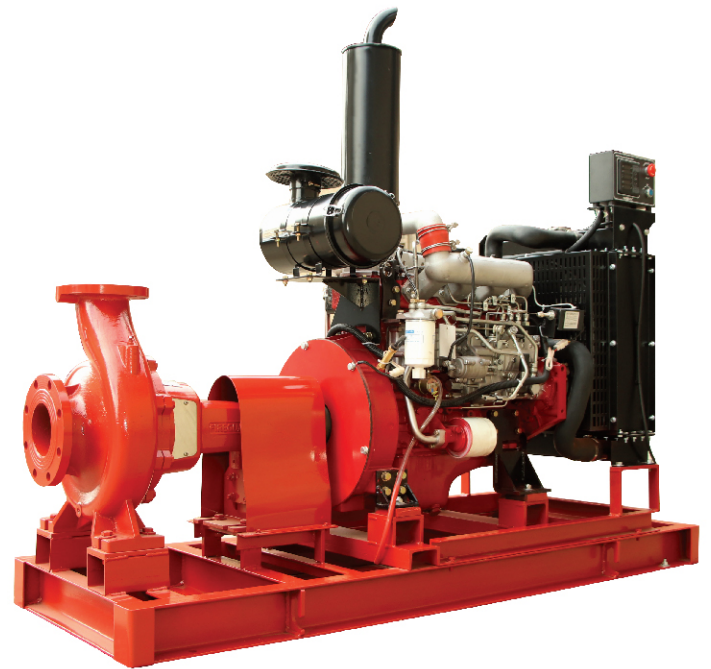

DESCRIPTION

- Diesel engines have proven to be very reliable and effective for driving standby fire pump.
- Diesel engines are from type of internal combustion engine permitted by NFPA 20.
- Each engine is provided with battery unit according to NFPA20.
- Advanced direct injection combustion chamber.
- Turbo charger for large capacity.
- Dedicated chassis for easy transportation, installation and handling.
- Dedicated Controller.
- Dedicated monitoring unit to follow up working parameters .
- Low vibration and Low noise design.
- Protection guard for moving parts.

Diesel Engine FGD

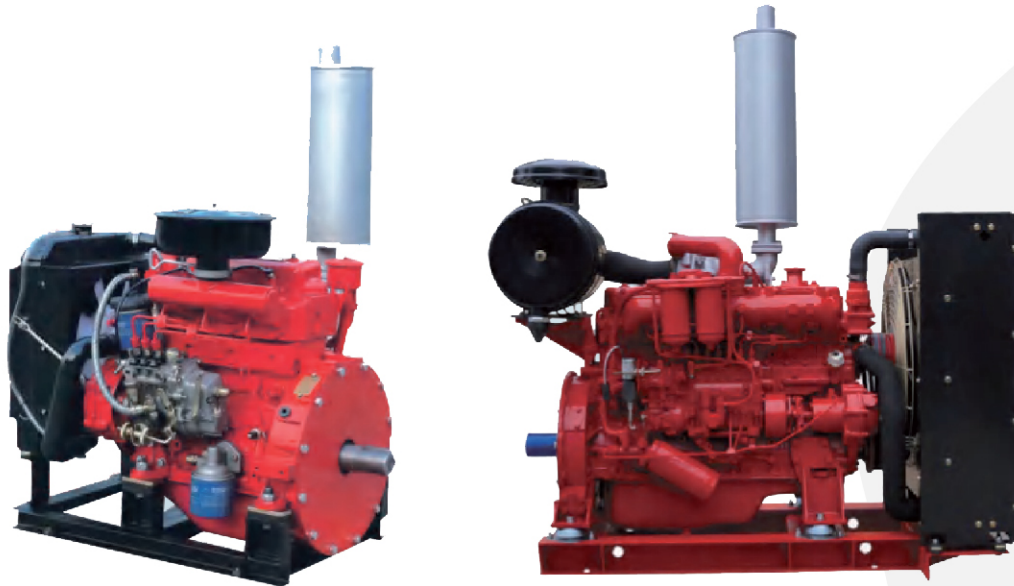

DESCRIPTION

- Water-cooling 3-to 6-cylinder naturally or turbo charging aspiration.
- Advanced direct injection combustion system.
- Extremely compact dimensions, easy to maintain and low space occupation.
- Noise reduction optimized technology and stronger power.
- Low fuel consumption and environmental protective.

TECHNICAL DATA

Model	178	186	188	192	380	385	480	485	490N	490	495	498	4102	4105	4108
Type	4 strokes,Air cooling					Direct Injection,4 strokes, Water-cooling									
Intake Type	Naturally Aspirated														
Bore*Stroke(mm)	78*62	86*72	88*75	92*75	80*90	85*90	80*90	85*100	90*100	90*105	95*105	98*105	102*118	105*118	108*118
Cylinder No.	1	1	1	1	3	3	4	4	4	4	4	4	4	4	4
Displacement	0.296L	0.41 8L	0.456L	0.499L	1.357L	1.532L	1.8L	2.27L	2.54L	2.67L	2.977L	3.168L	3.857L	4.087L	4.324L
r/min	3000 3600	3000 3600	3000 3600	3000 3600	3000	3000	3000	3000	3000	3000	3000	3000	3000	3000	3000
Rated kW	3.7kW 4.0kW	5.7kW 6.3kW	6.6kW 7.2kW	7.5kW 8.2kW	20kW	24kW	28kW	36kW	42kW	45kW	50kW	54kW	62kW	67kW	73kW
Rated HP	5.0HP 5.5HP	7.8HP 8.6HP	9HP 10HP	10.2HP 12HP	27HP	32HP	38HP	49HP	58HP	61HP	68HP	73HP	85HP	91HP	99HP
Fuel Consumption (g/kw.h)	280.3 282.5	273.5 285.7	273.5 285.7	275 281	228	228	215	228	228	228	228	228	228	238	238
Start Voltage	12V	12V	12V	12V	12V	12V	12V	12V	12V	12V	12V	12V	12V	24V	24V
Speed regulation type	Mechanical														
Including	Radiator, Fan, Starter, charge alternator, Air filter, Muffler, Stop Solenoid, PTO shaft, Fuel Tank, Meter Panel														

TECHNICAL SHEET

Model	FGVT 4-12
Capacity	250 GPM
Head	8 bar
H max (Cut off head)	8.95 bar
DN	32*32 mm
Speed	2900 rpm
T max	100°C
Power	2.2kW - 3HP
Casing	Gray cast iron
Impeller	Stainless steel 304
Shaft	Stainless steel 304
Sealant	Mechanical Seal
Bearing	Grease lubrication rolling bearing
Voltage	220/380 V
Protection degree	IP55
Motor winding insulation class	F
Power connection	D.O.L
Current	8.2/4.7
Duty	S1 continuous
HZ	50

Jockey

Jockey pump maintains the necessary pressure in the system and make up leakage.

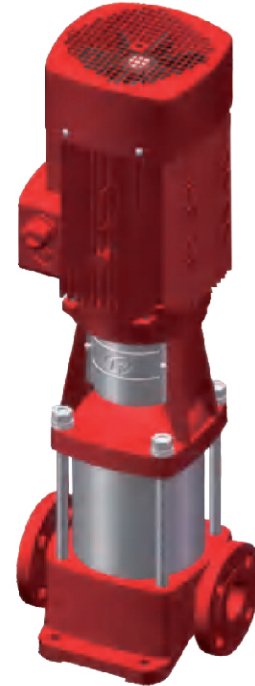

DESCRIPTION

- The jockey pump is designed to maintain the pressure on the fire fighting piping network pressure system.
- Rated capacity not less than 1 sprinkler flow rate and not more than 10% of main pump flow.
- Discharge pressure sufficient to maintain the desired fire fighting system pressure.
- SS304 vertical, multistage centrifugal pump.
- The suction and discharge ports are on same level.
- FGVT pump head and base are cast iron.
- FGVS pump all wetted parts are in stainless steel.
- Quality bearing and wear resistance mechanical seal.
- Liquid temperature between -10°C and +120°C.

MATERIAL DESCRIPTION

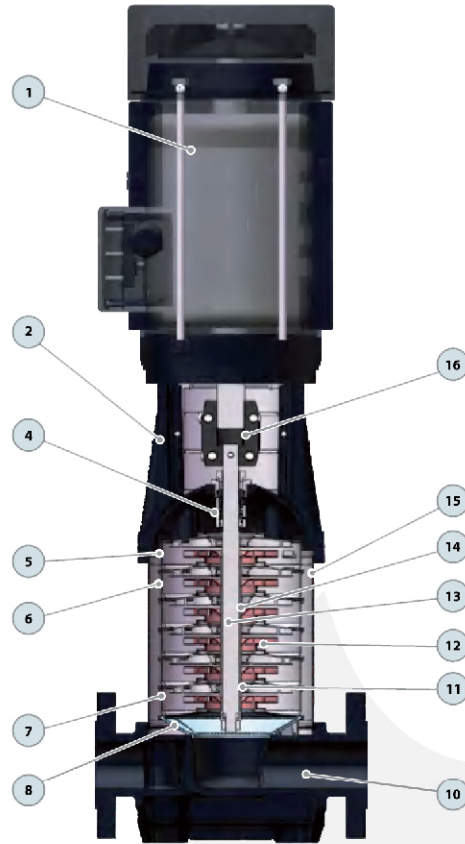

FGVT

No.	Description	Material	No.	Description	Material
1	Motor	IP55 Class F	9	Base Plate	Cast iron
2	Pump Case	Cast iron	10	Inlet&Outlet Chamber	PVT:Cast iron PVS:SS304
3	Seal Base	SS304	11	Bearing	Tungsten Carbide
4	Mechanical Seal	SS304	12	Impeller	SS304
5	Top Diffuser	SS304	13	Shaft	SS304
6	Diffuser	SS304	14	Impeller Sleeve	SS304
7	Support Diffuser	SS304	15	Cylinder	SS304
8	Inducer	SS304	16	Coupling	Carbon Steel



Controller

The fire pump control panel performs the following functions:

- A) Input: Receives signals from alarm devices such as pressure operated switches or remote fire alarm equipment.
- B) Output:
 - a. Provides electrical power to actuate the motor.
 - b. Send signal to actuate the diesel engine.
- C) Monitoring: Monitors the fire pump operation and performance.

All controllers are completely assembled, wired and tested by the manufacturer before shipment from factory.

The pump consists of three separate controllers; electric, diesel and jockey controllers.

Electrical components such as circuit breaker, switches, relays and other devices dedicated to the operation of fire pumps are SCHNEIDER products.

DESCRIPTION

- Equipped with integrated digitalization, and network technologies for precise data measurement, alarm protection, remote control, measuring and communication.
- DOL, Star Delta starter or soft starter based on load or client requirement.
- All controllers are completely assembled, wired and tested .
- Self-acting to start, run and protect the driver.
- Automatic or manual operation options.
- Degree of protection IP55.
- 3 indicating lamp for phase status.
- Available phase failure/phase sequence relay for larger capacity.
- Available ammeter and voltmeter for larger capacity.
- Available over/under voltage relay for larger capacity.
- Custom made design based on request.
- Soft starter for larger capacity or upon request.

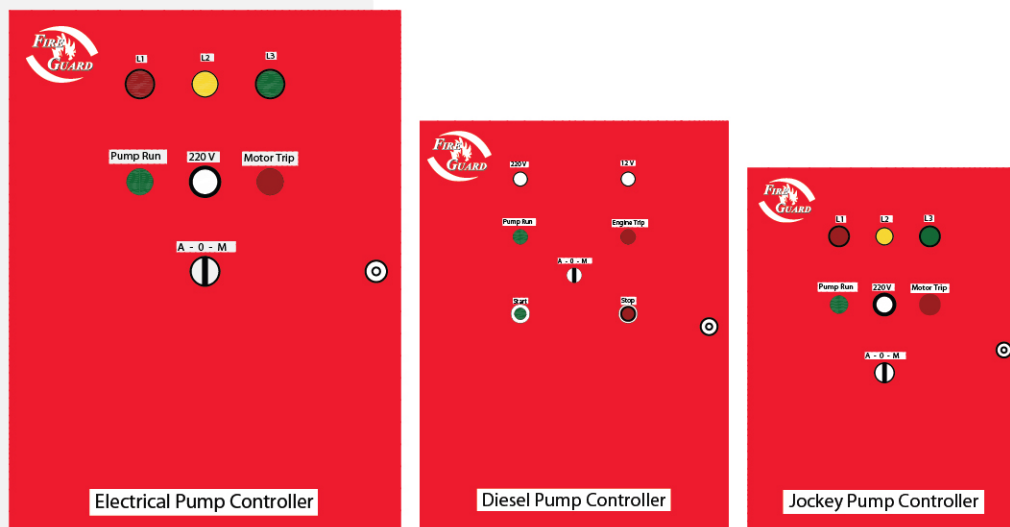

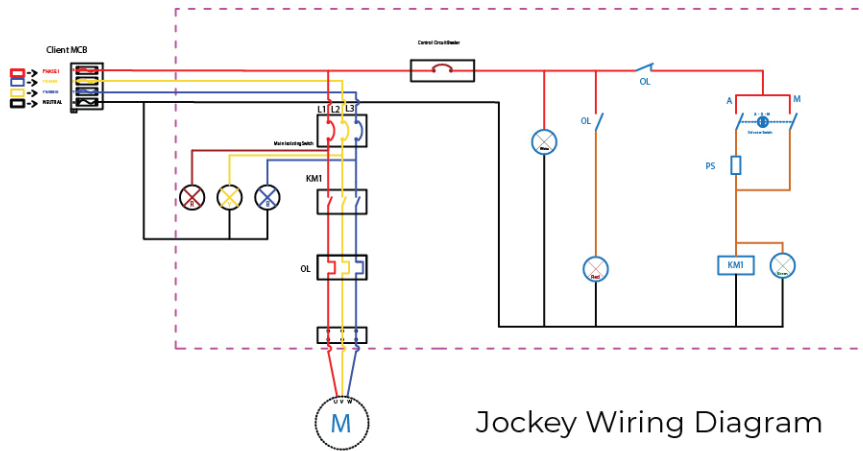

Jockey Wiring Diagram

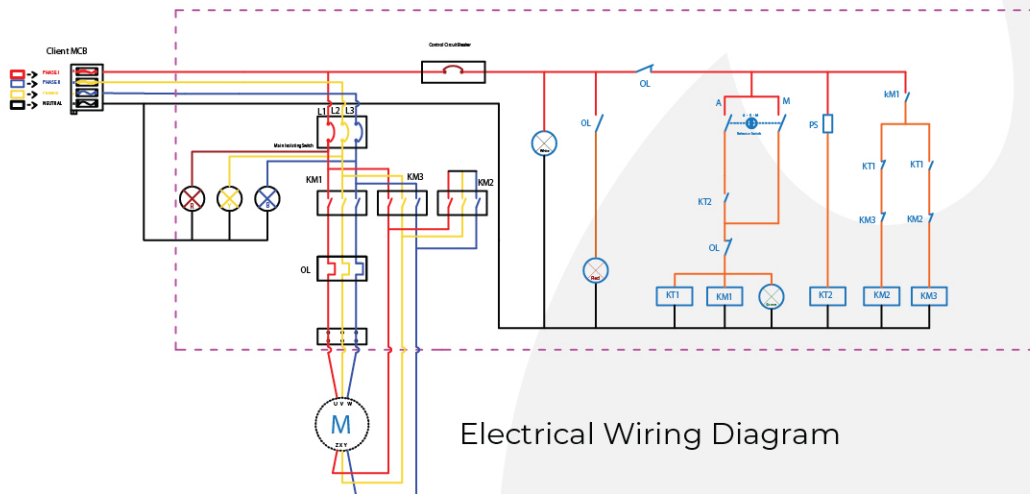

Electrical Wiring Diagram

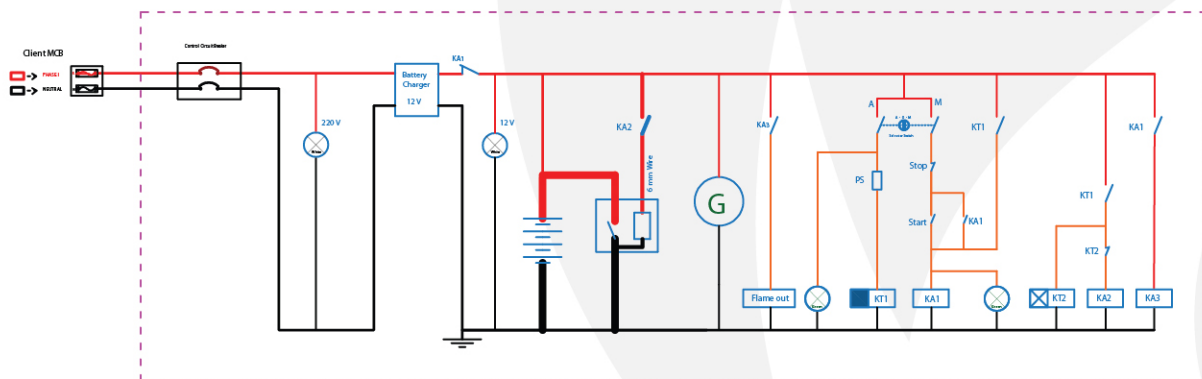

Diesel Wiring Diagram



PUMP SYSTEM



www.fireguard-uk.com

2900rpm

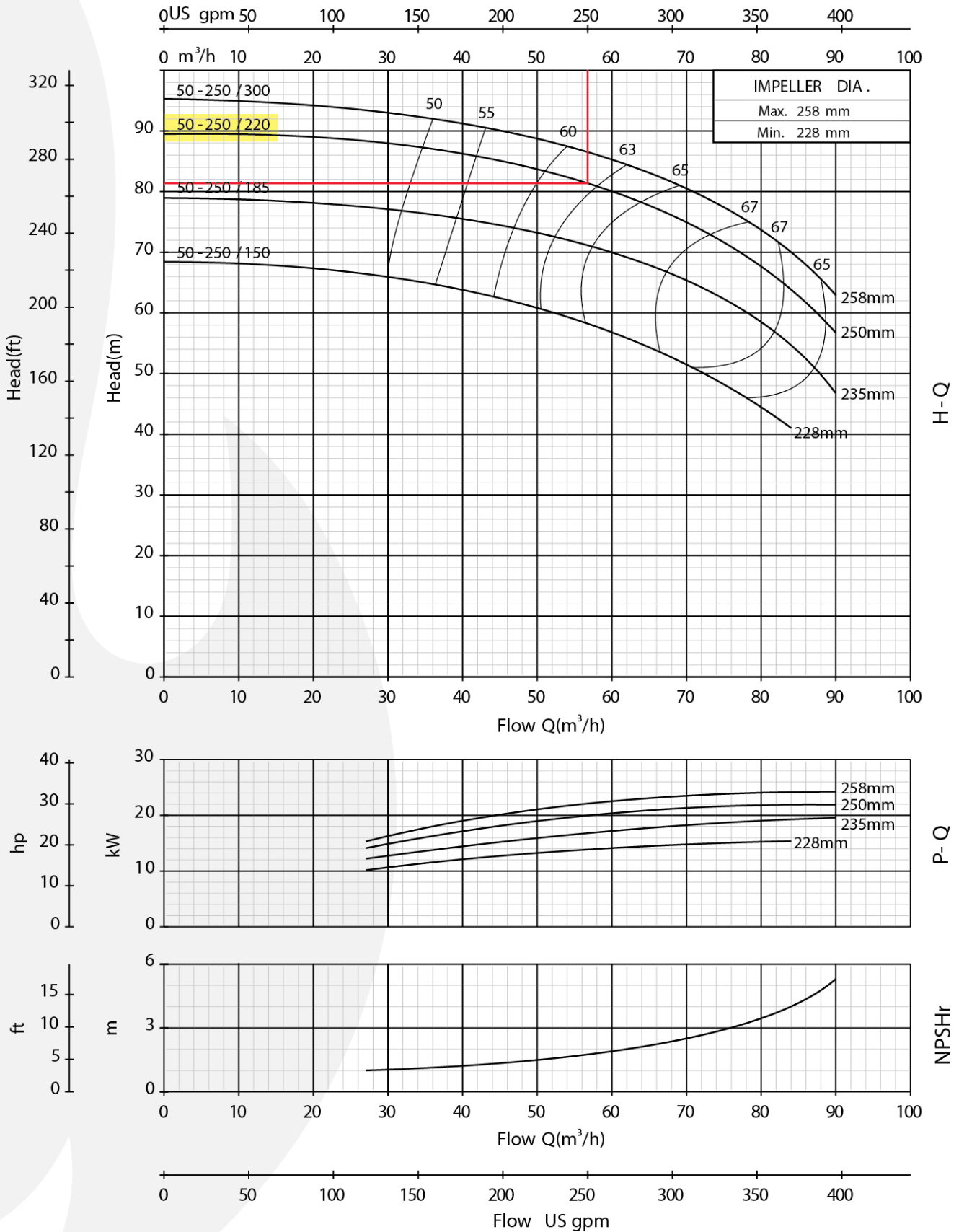



FGVT 4

2900rpm

