



BLADDER TANK

200 TO 15000 LITERS

PRODUCT OVERVIEW

FIREGUARD Bladder Tank Foam Proportioning System utilises the water pressure to inject foam concentrate into a water supply and automatically proportions foam concentrate over wide range of flow and pressure, with very low pressure drop. This system does not require a foam concentrate supply pump.

SPECIFICATIONS

The Bladder Tank Foam Proportioning System are available with vertical and horizontal bladder tanks. The carbon steel tanks are designed and constructed in accordance with ASME Code Section VIII Div.1 for unfired pressure vessels. The maximum working pressure is 12 Bar (175 PSI). The vertical tank assembly is supported by legs welded to tank with provision for anchoring. The horizontal tanks are supported by two saddles welded to the tank and drilled for anchoring. Tank is provided with lifting lugs. The system is supplied with pressure vessel, bladder, fill and drain valve for water and foam concentrate, ratio controller and vent valve. Ladder and sight gauge assembly are supplied as optional items on request. All valves are labeled showing normal working position and function. All tanks are oversized for allowing thermal expansion of the foam concentrate, if any.



TECHNICAL DATA

TANK MOUNTING TYPE	Vertical or Horizontal
CONCENTRATE STORAGE CAPACITY	For Vertical Tank 200 liters to 7500 liters (53 TO 2000 Gallon (US)) For Horizontal Tank 200 liters to 15000 liters (53 to 4000 Gallon (US))
MAXIMUM WORKING PRESSURE	12 Bar (175PSI) Standard Supply Higher pressure rating can be given on request
FACTORY HYDRO TEST PRESSURE	As per ASME code
VESSEL CONSTRUCTION	Carbon Steel as per ASME Code Section VIII Div 1, for unfired pressure vessels
“U” STAMP	Optional
BLADDER	Buna-N
CENTRE TUBE	Perforated PVC

EXTERNAL PIPING	Water side: Carbon Steel seamless pipe sch 40 Foam concentrate side: Stainless Steel sch 40
RATIO CONTROLLER	Wafer type with Stainless Steel 304/CF8 standard material Optional: Stainless steel 316/CF8M or Bronze
VENT AND DRAIN	Ball valve
APPROVALS	UL-Listed
OPTIONAL SUPPLY	Refer to page 3
FINISH	Red RAL 3000
ORDERING INFORMATION	Specify: 1) Tank type, vertical or horizontal 2) Storage capacity 3) Model number, size of ratio controller with flow and pressure 4) Type of foam concentrate to be used and percentage of induction required 5) Optional items

FIREGUARD GLOBAL LTD.

Tel: 00-44-8450751042 • Fax: 00-44-8459751043
Email: Info@Fireguard-Uk.com • www.fireguard-Uk.com

Unit 11 • Chancel Industrial Estate • Newhall Street
Willenhall • WV13 1NX • United Kingdom



FS546607



PRINCIPLE OF OPERATION

The instructions for filling are provided with the equipment. Once the main water flow is established and water inlet and foam outlet valves are opened, the water enters the area between vessel wall and bladder, applying pressure to the bladder. The foam concentrate is forced out of the bladder through the foam concentrate outlet pipe and into the ratio controller through metering orifice. The concentrate pressure and water inlet pressure at ratio controller will be same, as the main water supply pressure is utilised to expel the foam from the bladder. The water flowing through the ratio controller jet creates a low pressure area common both to down stream water and foam concentrate. This injects the concentrate in to the ratio controller through an accurate sized orifice proportioned to water venturi. This ensures correct proportioning over a wide range of flow condition.

The bladder tank proportioning system operates on same principle as that of a balance pressure proportioning system. In bladder system, the bladder is used as diaphragm to separate the water and foam concentrate within the tank. The foam concentrate is injected into the ratio controller utilising water pressure.

The system is also supplied with foam concentrate control valve as an optional item. The valve allows concentrate flow only when minimum of 2.1 kg/sq.cm. water pressure is established in the system. For pressure drop and flow characteristics refer catalogue of ratio controller.

SELECTION OF HORIZONTAL/VERTICAL BLADDER TANKS

- (i) Advantages of Horizontal bladder tanks 6 Better stability than vertical tank in earthquake prone area
- (ii) Easier to refill than vertical tanks
- (iii) Easy to transport, store and install
- (iv) Large Capacity

Advantages of Vertical bladder tanks

- (i) Require less floor space than horizontal tanks

INSTALLATION, INSPECTION AND MAINTENANCE

An installation, inspection and maintenance manual is packed with each unit. The manual provides detail schematic, initial procedure, inspection and maintenance procedures.

The instruction manual must be read carefully and followed during installation and commissioning of the system. After few initial successful tests an authorised person must be trained to perform inspection and testing of the system. It is recommended to carry out physical inspection of the system regularly, the inspection should verify that no damages have taken place to any component and all the valves are in their proper position as per the system requirement. The system should be fully tested at least once in a year and in accordance with applicable NFPA code or in accordance to the guidelines of the organisation having local jurisdiction. Do not turn off the system or any valve to repair or test the system, without placing a roving Fire Patrol in the area covered by the system. The patrol should continue until the system is put back in service. Also inform the local security personnel and the control room so that a false alarm is not signalled.

CAUTION

- 1) Do not weld on the tank as it may damage the bladder fitted inside the tank.
- 2) Release pressure before an inspection and maintenance of the system.
- 3) Sight gauge is not pressure tight, so before taking concentrate level reading, tank pressure must be released.
- 4) The bladder tank is to be installed under a shade to avoid direct sunlight on the equipment.
- 5) While designing a foam system, step shall be taken to allow for removal of the internal centre tubels). The centre tubes are full length and/or height of the bladder tank.
- 6) ASME Code may require over pressure protection before pressurising the system. FIREGUARD does not supply an over pressure relief valve with the tanks. It shall be the owner's responsibility to provide over pressure protection for the tank in accordance to ASME Code.
- 7) Foam concentrate filling procedure must be followed. Incorrect filling procedure may damage the bladder. Fireguard product have limited warranty and incorrect fill procedure will void the warranty.

NOTE

- 1) The foam concentrate is to be filled in the bladder very carefully to avoid rupture of the bladder. The filling guidelines provided with the equipment must be strictly adhered
- 2) Air supply with regulator (0 to 1.0 kg/sqcm) required during filling procedure, to be arranged by installer /user.





- 3) Water supply at 0-1.5 kg/sqcm required for tank filling during commissioning, to be arranged by installer /user.
- 4) Concentrate fill pump need to be arranged by installer /user.
- 5) A minimum length of 5 (five) times the pipe diameter of unobstructed straight pipeline should be provided at the inlet and outlet of the ratio controller, where pipe diameter is the nominal size of the ratio controller.

OPTIONAL SUPPLY

- Sight gauge with shut off and drain valve (glass or polycarbonate material)
 - Ladder
 - Concentrate control valve
 - Filling kit
 - Stainless steel pipe for water supply side
- Stainless steel pipe & valve standard supply SS304/CF8. Optional is SS316/CF8M or SS316L
- Painting as per specific requirement
 - Seismic designed tanks
 - Custom designed for higher rating, material and dimension
 - Coal Tar epoxy internal coated, standard supply or any other paint as per customer requirement

- Ratio controller material Bronze, Stainless steel CFB, CF8M
- Relief valve is not included in standard supply it is optional as per specific customer requirement

RELIEF VALVE (OPTIONAL SUPPLY)

- (i) Thermal Relief valve
- (ii) Full flow, as per ASME Gi
- (iii) Full flow, ASME "U" Stamped

LISTING & APPROVAL

- 1) Bladder tank proportioning system is UL-Listed as pre-piped system.
- 2) Listing and Approval is valid only when used in the manner as outlined in the applicable Listing and Approval.

SHIPPING DETAILS

- (i) All the tank openings will be plugged for shipping.
- (ii) All pre-piped pipes, valves, pressure gauges, sight gauge etc will be packed separately for shipping.
- (iii) Tank will be mounted on pallet with crate all over as standard packing system of FIREGUARD. For any custom packing requirement contact FIREGUARD Sales.



VERTICAL BLADDER TANK PROPORTIONING MANUAL SYSTEM

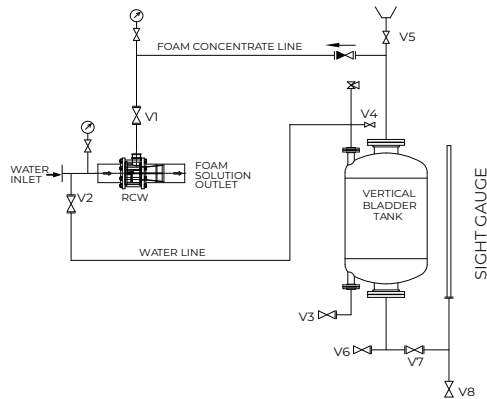

VERTICAL BLADDER TANK PROPORTIONING AUTO SYSTEM

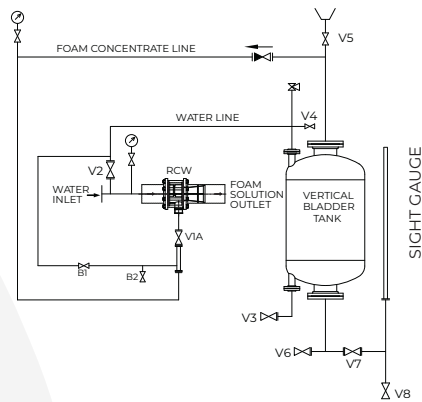

VALVE NO.	DESCRIPTION	NORMAL POSITION	
		MANUAL SYSTEM	AUTO SYSTEM
V1	FOAM CONCENTRATE SHUT OFF VALVE	CLOSED	----
V1A	AUTO FOAM CONCENTRATE SHUT OFF VALVE	----	CLOSED
V2	WATER PRESSURE SHUT OFF VALVE	OPEN	OPEN
V3	TANK WATER DRAIN VALVE	CLOSED	CLOSED
V4	TANK WATER VENT VALVE	CLOSED	CLOSED
V5	CONCENTRATE VENT	CLOSED	CLOSED
V6	CONCENTRATE FILL / DRAIN VALVE	CLOSED	CLOSED
V7	SIGHT GAUGE FILL VALVE	CLOSED	CLOSED
V8	SIGHT GAUGE DRAIN VALVE	CLOSED	CLOSED
B1	MANUAL OVER RIDE VALVE	----	OPEN
B2	RESTING VALVE	----	CLOSED

SYMBOLS & ABBREVIATION

	NON RETURN VALVE		PRESSURE GAUGE
	VALVE		FUNNEL
	SAFETY VALVE		RATIO CONTROLLER

HORIZONTAL BLADDER TANK PROPORTIONING MANUAL SYSTEM

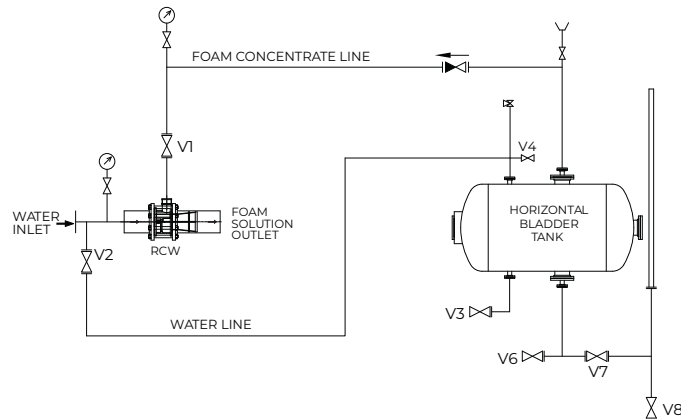

HORIZONTAL BLADDER TANK PROPORTIONING AUTO SYSTEM

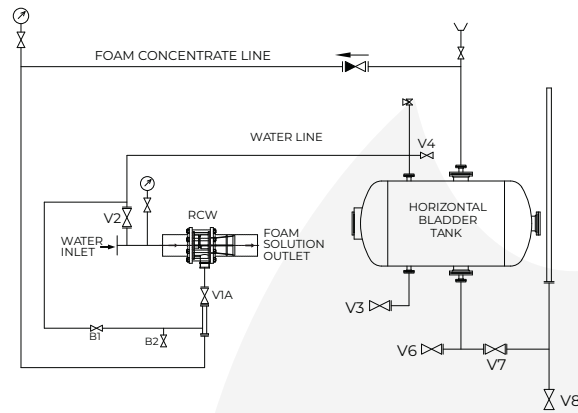

VALVE NO.	DESCRIPTION	NORMAL POSITION	
		MANUAL SYSTEM	AUTO SYSTEM
V1	FOAM CONCENTRATE SHUT OFF VALVE	CLOSED	----
V1A	AUTO FOAM CONCENTRATE SHUT OFF VALVE	----	CLOSED
V2	WATER PRESSURE SHUT OFF VALVE	OPEN	OPEN
V3	TANK WATER DRAIN VALVE	CLOSED	CLOSED
V4	TANK WATER VENT VALVE	CLOSED	CLOSED
V5	CONCENTRATE VENT	CLOSED	CLOSED
V6	CONCENTRATE FILL / DRAIN VALVE	CLOSED	CLOSED
V7	SIGHT GAUGE FILL VALVE	CLOSED	CLOSED
V8	SIGHT GAUGE DRAIN VALVE	CLOSED	CLOSED
B1	MANUAL OVER RIDE VALVE	----	OPEN
B2	RESTING VALVE	----	CLOSED

SYMBOLS & ABBREVIATION

	NON RETURN VALVE		PRESSURE GAUGE
	VALVE		FUNNEL
	SAFETY VALVE		RATIO CONTROLLER