



MOBILE FOAM UNIT

TECHNICAL DATA

MODEL	MF Stainless Steel MF-A Fibre Glass Tank
FOAM CONCENTRATE STORAGE CAPACITY	160 Ltrs. Model-MF-A 120 to 220 Ltrs. Model-MF
FOAM INDUCTOR	225 or 450 LPM capacity at 7 kg. / sq.cm. pressure Induction - 3%
MATERIAL	Concentrate tank: MF - Stainless Steel MF-A - With Fibre Glass Tank Inductor - Bronze or SS Branch pipe - Aluminium Hose - Optional supply as per requirement Concentrate - Optional supply as per requirement
WHEEL	Rubber wheel
FINISH	Yellow
ORDERING INFORMATION	Specify 1) Model and material of construction for storagetank 2) Type of concentrate & hose requirement 3) Concentrate storage capacity

APPLICATION

Mobile Foam Unit is used for effective quick application of foam to fight spill fires in high risk areas such as storage tanks, loading terminals, port areas and similar high risk zones.

SPECIFICATION

It is a self contained unit with foam inductor, foam branch pipe, foam concentrate storage tank, and two length of fire hoses. It requires only connection to a suitable water supply. It is easy to operate, move and requires minimum manpower.

Foam concentrate storage tank is made out of fiber glass / stainless steel. The foam branch pipe and fire hoses are mounted on the concentrate storage tank. The foam inductor is clamped rigidly on the storage tank. The complete unit is mounted on two wheels with a handle for easy movement.



TESTING AND MAINTENANCE

After few initial successful tests, an authorised person must be trained to perform inspection and testing of the unit. It is recommended to carry out physical inspection of the unit, the inspection should verify that no damage has taken place to any component of the unit. Each unit must be operated with full flow frequently in accordance to the guidelines of the organisation having local jurisdiction. The owner is responsible for maintaining the equipment in proper operating condition.

CAUTION

Appropriate guidance and training must be given to authorised person for proper operation of equipment Application of water or foam on an electric appliance can cause injury. The water supply to unit must be increased gradually, a sudden surge of water supply to the unit must be avoided.

FIREGUARD GLOBAL LTD.

Tel: 00-44-8450751042 • Fax: 00-44-8459751043

Email: Info@Fireguard-Uk.com • www.fireguard-Uk.com

Unit 11 • Chancel Industrial Estate • Newhall Street
Willenhall • WV13 1NX • United Kingdom



MODEL MF

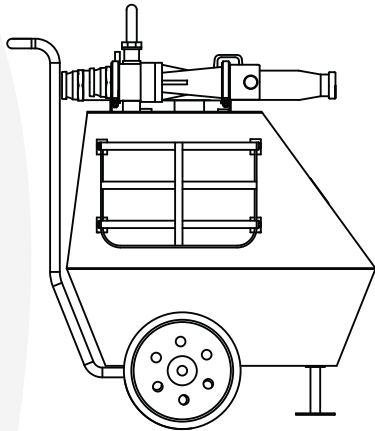

ELEVATION

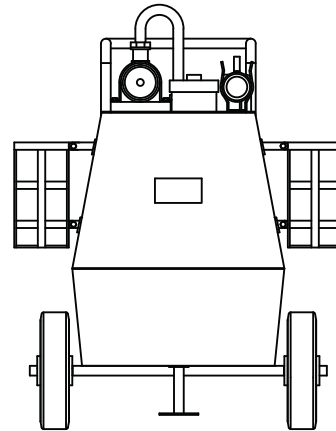

SIDE VIEW

MODEL MF-A

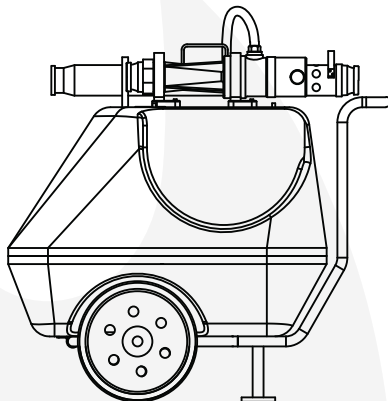

ELEVATION

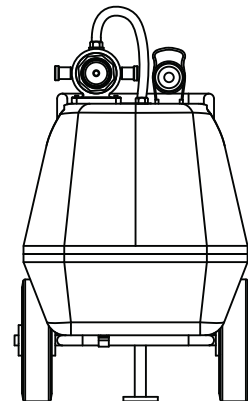

SIDE VIEW

LIMITED WARRANTY

HD FIRE PROTECT PVT. LTD. hereby referred to as HD FIRE warrants to the original purchaser of the fire protection products manufactured by HD FIRE and to any other person to whom such equipment is transferred, that such products will be free from defect in material and workmanship under normal use and care, for two (2) years from the date of shipment by HD FIRE. Products or Components supplied or used by HD FIRE, but manufactured by others, are warranted only to the extent of the manufacturer's warranty. No warranty is given for product or components which have been subject to misuse, improper installation, corrosion, unauthorized repair, alteration or HD FIRE shall not be responsible for system design errors or improper installation or inaccurate or incomplete information supplied by buyer or buyer's representatives. HD FIRE will repair or replace defective material free of charge, which is returned to our factory, transportation charge prepaid, provided after our inspection the material is found to have been defective at the time of initial shipment from our works. HD FIRE shall not be liable for any incidental or consequential loss, damage or expense arising directly or indirectly from the use of the product including damages for injury to person, damages to property and penalties resulting from any products and components manufactured by HD FIRE. HD FIRE shall not be liable for any damages or labour charges or expense in making repair or adjustment to the product. HD FIRE shall not be liable for any damages or charges sustained in the adaptation or use of its engineering data & services. In no event shall HD Fire's product liability exceed an amount equal to the sale price. The foregoing warranty is exclusive and in lieu of all other warranties and representation whether expressed, implied, oral or written, including but not limited to, any implied warranties or merchantability or fitness for a particular purpose. All such other warranties and representations are hereby cancelled.

NOTICE:

The equipment presented in this bulletin is to be installed in accordance with the latest publication standards of NFPA or other similar organisations and also with the provision of government codes or ordinances wherever applicable. The information provided by us is to the best of our knowledge and belief, and consist of general guidelines only. Site handling and installation control is not in our scope. Hence we give no guarantee for result and take no liability for damages, loss or penalties whatsoever, resulting from our suggestion, information, recommendation or damages due to our product. Product development is a continuous programme of HD FIRE PROTECT PVT. LTD. and hence the right to modify any specification without prior notice is reserved with the company.