



TEST AND DRAIN VALVE

MODEL FGT 1000- 300psi

Test & Drain with an integral sight glass assembly, provides a simplified means for testing of waterflow alarm devices and draining of feed mains.

Test and drain valve is a 300 PSI rated single handle ball valve that was specifically designed to provide both the test function and the express drain function required for a wet fire sprinkler system.

It includes tamper resistant test orifice and sight glass for maximum visibility when operated.

Available in size 1" , 1 ¼" , 1 ½" & 2".

General Specifications

- Model : FGT 1000
- K-Factor : K5.6(80), K8.0(115)
- Dimensions Nominal : 1" - 2" / DN25 – DN50
- Pressure Working : 300 psi (20,7 bar)
- Temperature : -10 °C / +120 °C

Standards

- Certificate : UL & FM
- Design : UL258-2004
- Thread Design : ISO 228/1
- Tests : UL258-2004

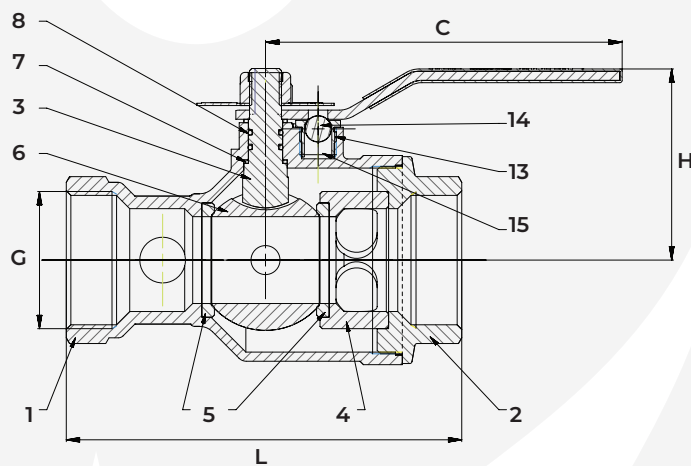
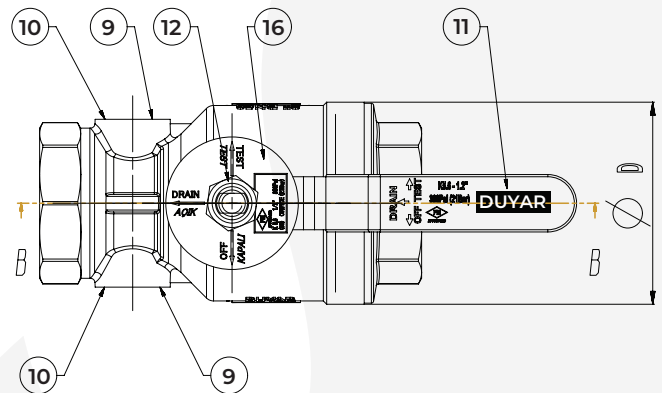
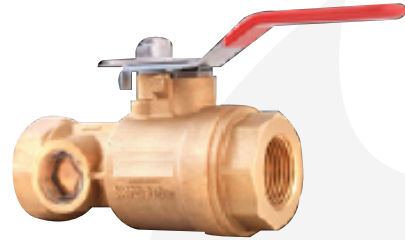

Dimensions

Nominal Pressure	300 psi (20,7 bar)		
Nominal Diameter	DN	25-32	40-50
Valve Dimensions	G	1" - 1 1/4"	1 1/2" - 2"
	L	133	173
	C	126	156
	H	65	84
	D	60	92
Weight	KG.	1.4/1.3	3.5/3

FIREGUARD GLOBAL LTD.

Tel: 00-44-8450751042 • Fax: 00-44-8459751043

Email: Info@Fireguard-Uk.com • www.fireguard-Uk.com

Unit 11 • Chancel Industrial Estate • Newhall Street
Willenhall • WV13 1NX • United Kingdom



FS546607

Material Specifications

NO	Part Name	Qty	Material
1	Body	1	CW617N / Brass
2	Bonnet	1	CW617N / Brass
3	Stem	1	AISI-304 / Stainless Steel
4	Bonnet Extension	1	CW617N / Brass
5	Ball Seat	2	PTFE
6	Ball	1	CW617N / Brass
7	Stem Seal	2	PTFE
8	O-Ring Seal	2	EPDM
9	Sight Glass	2	Acrylic
10	Sight Glass Gasket	2	EPDM
11	Lever	1	St37/Steel (Vinyl Coated)
12	Nut With Fiber	1	6.8 / Steel
13	Bearing Ball Centering	1	C-1040 / Steel
14	Bearing Ball	1	AISI-304 / Stainless Steel
15	Spring	1	AISI-302 S. S / Spring Steel
16	Label Plate	1	AISI-304 / Stainless Steel

Test and Drain Valve Connection Details

